

**Hako – Citytrac 4200  
Hako – Citymaster 1200  
Hako - Citycleaner**

**Electrical Installations**

<b>Citytrac 4200 Citymaster 1200 Citycleaner</b>	<b>Service Documents</b> For internal use only	Status March 2009	Page 76	<b><i>Hako</i></b>
--	---	----------------------	------------	--------------------

## 6.1 Safety information

### **Attention!**

- When working on the engine and the electrical installations, always disconnect the battery (minus pole).

### **Notes on the three-phase generator**

- Only allow the engine to run with the battery connected.
- Do not use a charger as a cold start device.
- Disconnect the battery before starting any recharging or electric welding on the device.

<p><b>Citytrac 4200</b>  <b>Citymaster 1200</b>  <b>Citycleaner</b></p>	<p><b>Service Documents</b>  For internal use only</p>	<p>Status  March 2009</p>	<p>Page  77</p>	
---	--	-------------------------------	---------------------	---

## 6.2 Basic principles, electrical engineering circuit diagram (terminal plan/wiring diagram)

Circuit and wiring plans are always comprised of the drawings and reference lists.

The reference lists always contain all the machine components.

The letter assignment is organised as follows:

- A electronics, control units
- B sensors, transducers
- C capacitors
- E headlights, lighting, indicators
- F fuses
- G batteries, generators
- H control lamps
- K relays
- M starter, electric motors, stroke elements, pumps
- R resistors, potentiometers, glow plugs
- S switches, buttons
- V diodes
- X connectors, potential distributor
- Y valves, solenoid valves, proportional solenoid valves, magnetic clutches

Every component is identified by a letter and chronological number, e.g.: M1 relates to a starter, M2 a pump, M3 an electric motor, etc.

Plugs and connectors on electronic components are identified by A1; X1 or A1;X2.

Plugs and connectors with several pins are identified by A1; X1:1 or A1; X1:2 etc..

Connectors or potential distributors which are not located on an electronics component are only identified by X1, X2 etc.

<b>Citytrac 4200 Citymaster 1200 Citycleaner</b>	<b>Service Documents</b> For internal use only	<b>Status</b> March 2009	<b>Page</b> 78	<b><i>Hako</i></b>
--	---	-----------------------------	-------------------	--------------------

### **Circuit diagram:**

The circuit diagram depicts the connections between the individual components within the entire machine. The functional organisation of the system can be seen on the circuit diagram.

### **Wiring diagram:**

In addition to the information on the circuit diagram, the wiring diagram illustrates all the components, such as connectors, plugs, cables, cable harnesses etc., as they are installed in the corresponding machines. Each cable harness is identified by a number. This number can be used to order the respective cable harness from Hako (e.g. 97-06 415-8). Cable harnesses are produced individually according to customer orders.

## 6.3 Fuse box PCB

- F1 : Parking, rear light, right
- F2 : Parking, rear left license plate light
- F3 : Flashing alarm lamps, interior lighting
- F4 : Pre-fuse 58 / 50
- F5 : Pre-fuse 15
- F6 : Pre-fuse 75
- F7 : Control unit controller, seat contact
- F8 : Fan condenser (air-conditioning unit)
- F9 : 12 V socket, radio terminal 30
- F10: Heater fan, controller  
Air-conditioning unit
- F11: Y6 Circulation off
- F12: Operating hour counter, radio terminal 15
- F13: Hydraulic valves
- F14: Y13 Work mode / all-wheel off
- F15: Work circuit control unit, seat contact
- F16: Driving lights, front
- F17: Windscreen wiping/washing system
- F18: Work headlights
- F19: Engine control, K1 (75)
- F20: Indicators
- F21: Wedge plough, spreader, quick emptying
- F22: Proportional valve Y4 + Y5
- F23: Y11 Diff. lock, water pump
- F24: Hazard lights

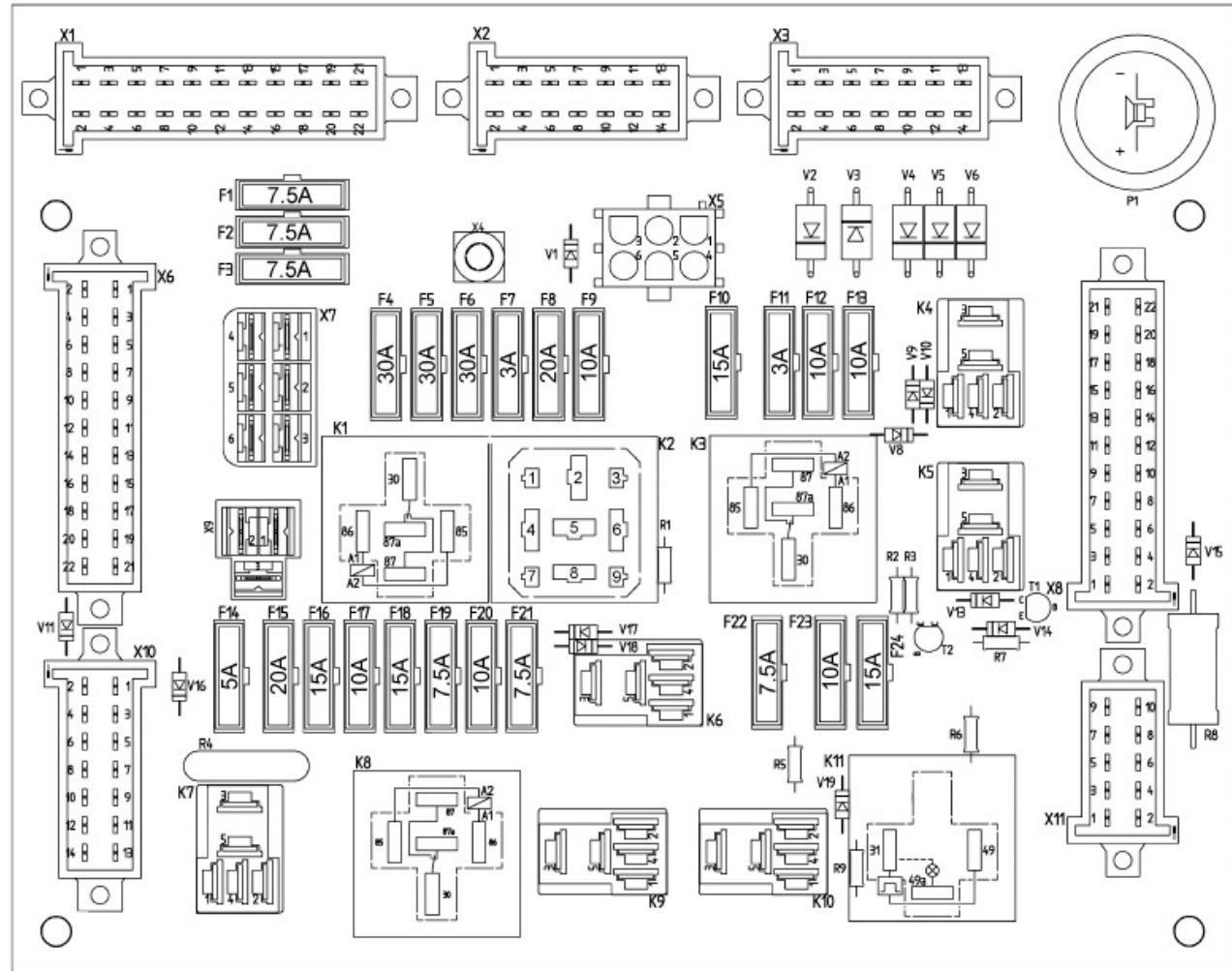

- K 1 : Relay voltage 75
- K 2 : Control unit, seat contact
- K 3 : Relay fan/clutch air-conditioning unit
- K 4 : Lock, front attachment support floating
- K 5 : Proportional valve connection
- K 6 : Work - Transport mode change-over
- K 7 : Restart protector, mower (locking)
- K 8 : Windscreen wiper interval (option)
- K 9 : Enable mower (seat contact B8 > mower switch S5)
- K10: Suction fan/mower relay on
- K11: Indicator relay

Identification	Name	Order No.
F1, F2, F3; F19; F21; F22	Fuse link C7.5 A	50-955
F9; F12; F13; F17; F20; F23	Fuse link C10 A	73-363
F10; F16; F18; F24	Fuse link C15 A	73-364
F8; F15	Fuse link C20 A	50-036
F4; F5; F6	Fuse link C30 A	15-206
F14	Fuse link C5 A	90-612
F7; F11	Fuse link C3 A	105-705
K1; K3	Small relay	74-477
K2	Control unit, seat contact	114-118
K4; K5; K6; K7; K9; K10	Relay with snubber resistor	114-117
K11	Indicator transducer	109-274

## 6.4 Fuse box, trailer

View of junction box

-K19, -K20 and -K22 (OPTION)  
mounted on junction box lid

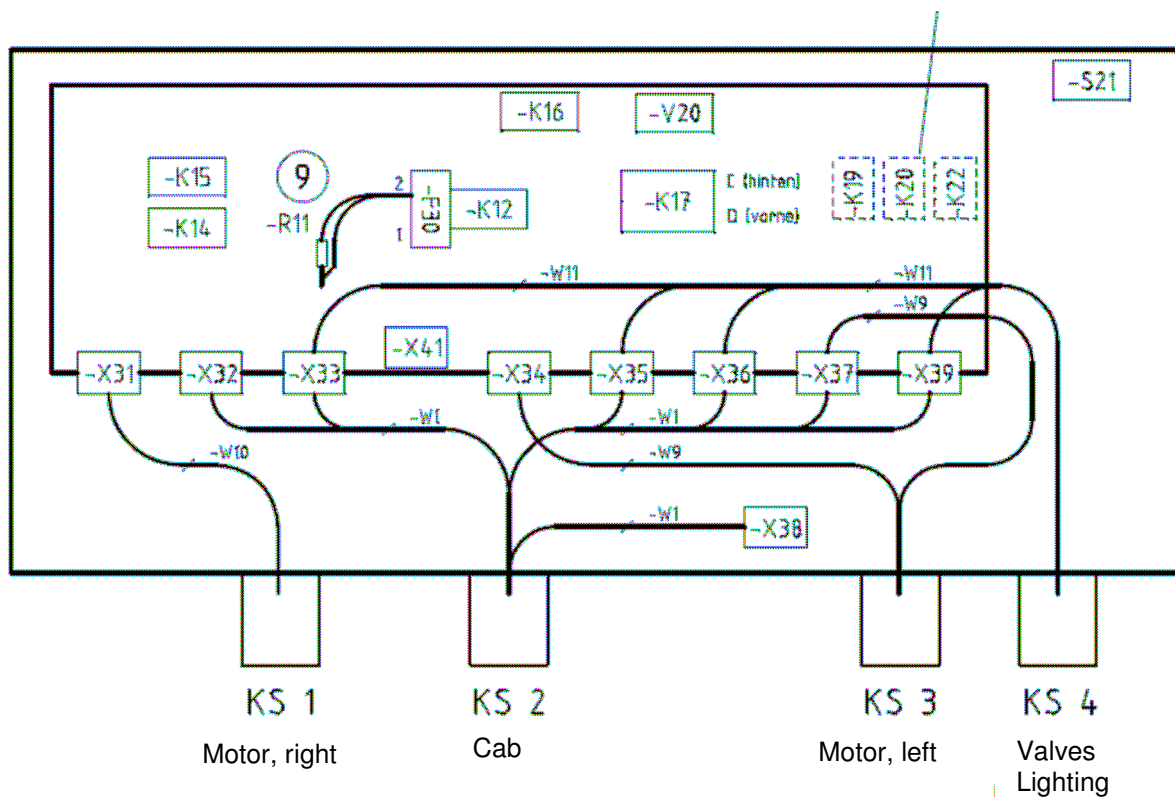

- F30 = Main fuse**  
00874760
- K12 = Preheating control unit**  
01144400
- K14 = Cooling water level control unit**  
01081390
- K15 = Cooling water level relay**  
00744770
- K16 = Timer, fuel valve**  
01141150
- K17 = Relay, fuel valve**  
01041700
- K19 = Relay, enable starter**  
00744770
- K20 = Relay, dynamo (option)**  
00744770
- K22 = Relay, reversing signal (option)**  
00744770
- R11 = Series resistor, preheating control unit**  
19245018
- S21 = Limit switch, container/platform**  
01161460
- V20 = Diode, fuel valve**  
01144370

## 6.5 Overview of electrical components

Gesamtansicht der Maschine

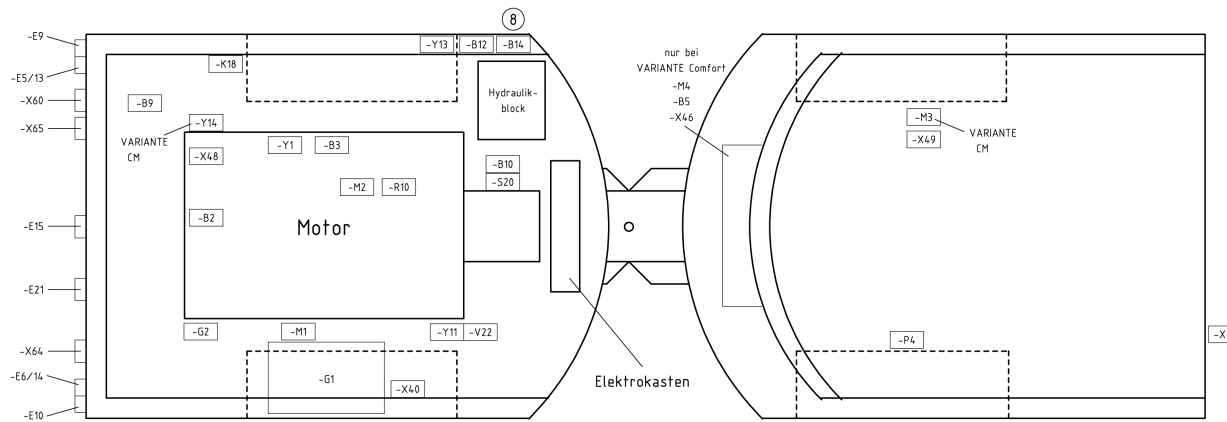

Front

Ansicht Elektrokasten

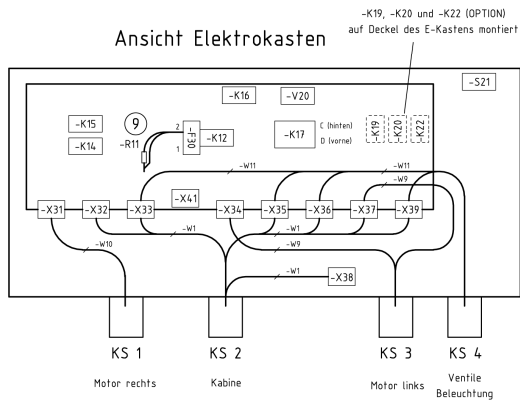

Ansicht Anlasser-Steuergerät

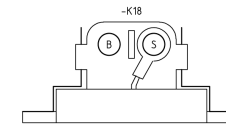

Ansicht Hydraulikblock

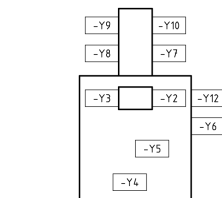

Front

Overview machine



Frontview cab

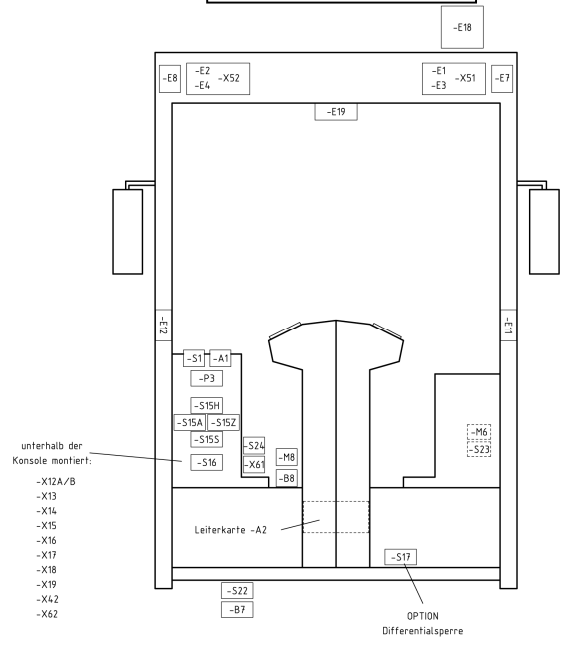

Look at circuit board A2

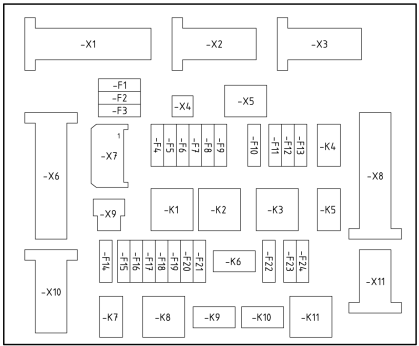

Connectors control unit A1

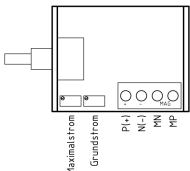

View steering column

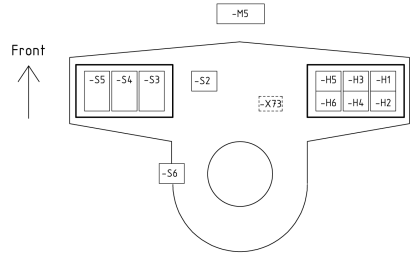

View roof consol (inside cab)

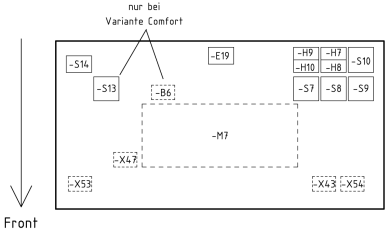

## 6.6 Front attachment device connector X63 7-pin

This connector serves mainly for enabling/disabling certain hydraulic functions  
Pins 1 – 5 are provided for this. Pin 6 is for the lighting and Pin 7 is the PE connection.

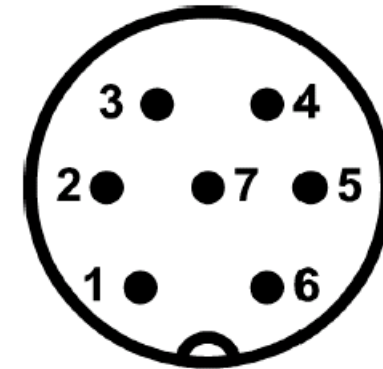
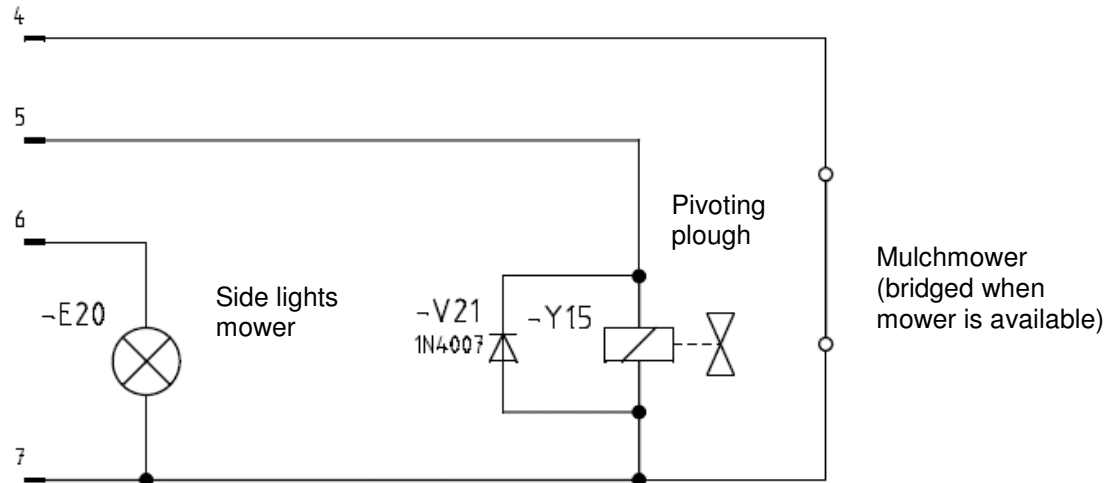

(View of pin contacts)

**Connector**  
Order no.: 114-372

**Service plug**  
Order no.: 114-438

<b>Citytrac 4200 Citymaster 1200 Citycleaner</b>	<b>Service Documents</b> For internal use only	Status March 2009	Page 85	<b><i>Hako</i></b>
--	---	----------------------	------------	--------------------

## **No jumpers**

Operation as Citytrac with mower

- The hydraulic circuit is only activated after switching on the “mower circuit”.
- The attachment switches off automatically when the front attachment support is raised.
- The hydraulic circuit is switched off immediately the driver leaves the seat and must be reactivated after the seat contact has been closed again by switching it "off and on again".

## **Jumper, pin 1 to pin 2:**

Optional operation as Citymaster or Citytrac (**not for mower operation**)

- The hydraulic circuit is only activated after switching on the “mower circuit”.
- When the front attachment support is raised, the attachment device runs again (till September 2008).
- The attachment switches off automatically when the front attachment support is raised (from September 2008).
- The hydraulic circuit is switched off one second after the driver leaves the seat and must be reactivated after the seat contact has been closed again by switching it "off and on again".

Can be used for attachment devices which should continue to run after being raised. Is not currently used by Hako.

### Jumper, pin 4 to pin 7:

Operation as Citymaster or Citytrac with mulchmower (hydraulic compound circuit) or spreader

- This enables the continual operation of the proportional hydraulic circuit.

The connector necessary to implement this bridging function belongs to the scope of delivery of the attachment device.

### Jumper pin 1 to pin 2; pin 2 to pin 3 and pin 4 to pin 7:

Operation as CM1200

- The hydraulic circuit is only activated after switching on the “mower circuit“.
- When the front attachment support is raised, the attachment device runs again (till September 2008).
- The attachment switches off automatically when the front attachment support is raised (from September 2008).
- The hydraulic circuit is **not** switched off when the driver leaves the seat.
- This enables the continual operation of the proportional hydraulic circuit.

There is a connector (cable harness W17) for this jumper which belongs to the functional scope of the brush unit. It is assigned spare part no. **01161150**

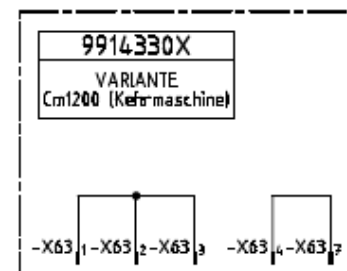
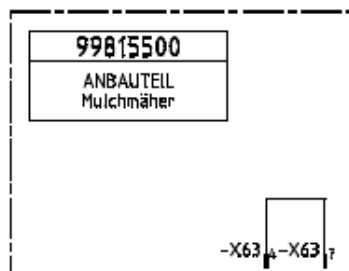

## 6.7 Rear attachment device connector X60 13-pin

This connector fulfils several functions. It serves the lighting, coding and power supply.

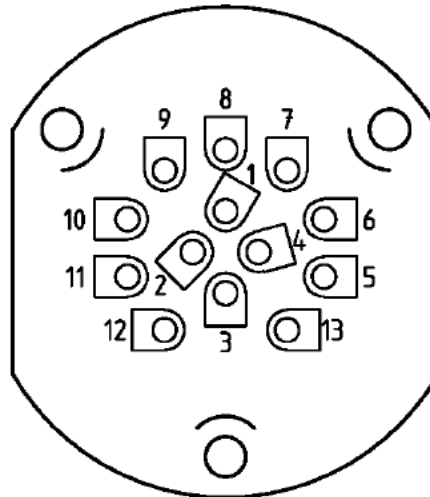

### Pin assignment

1	Drive direction indicator, left (L)	9	Not connected
2	Open at X13:1	10	Power supply for F23
3	Earth (31)	11	Earth (31)
4	Drive direction indicator, right (R)	12	Spreader coding
5	Rear light, right (58R)	13	Not connected
6	Brake lights (54)		
7	Rear light, left (58L)		
8	Reversing light (option)		

<b>Citytrac 4200</b> <b>Citymaster 1200</b> <b>Citycleaner</b>	<b>Service Documents</b> For internal use only	<b>Status</b> <b>March 2009</b>	<b>Page</b> <b>88</b>	<b><i>Hako</i></b>
--	---	------------------------------------	--------------------------	--------------------

### **Jumper, pin 3 to pin 12:**

Operation as Citymaster or Citytrac with path depending spreader

- This enables the continual operation of the proportional hydraulic circuit, depending of the way/speed

The connector necessary to implement this bridging function belongs to the scope of delivery of the attachment device.

## 6.8 Rear attachment device connector X64 7-pin

This connector fulfils several functions. It serves the lighting, coding and power supply.

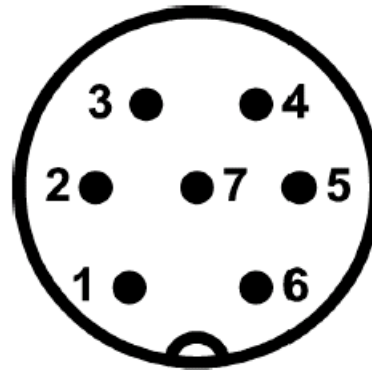

View of the pin contacts

### Pin assignment

- |   |                         |
|---|-------------------------|
| 1 | Speedometer             |
| 2 | Power supply for F23    |
| 3 | Open at X13:2           |
| 4 | Spreader coding         |
| 5 | Switch signal S16       |
| 6 | Rear light, right (58R) |
| 7 | Earth (31)              |

<b>Citytrac 4200 Citymaster 1200 Citycleaner</b>	<b>Service Documents</b> For internal use only	Status March 2009	Page 90	<b><i>Hako</i></b>
--	---	----------------------	------------	--------------------

### **Jumper, pin 4 to pin 7:**

Operation as Citymaster or Citytrac with grass and leaf vacuum

- This enables the continual operation of the proportional hydraulic circuit.

The connector necessary to implement this bridging function belongs to the scope of delivery of the attachment device. The connector (grass skip connection cable) to operate the grass-leaf vacuum 8380 has serial no. **97715767**.



<p><b>Citytrac 4200</b>  <b>Citymaster 1200</b>  <b>Citycleaner</b></p>	<p><b>Service Documents</b>  For internal use only</p>	<p>Status  <b>March 2009</b></p>	<p>Page  <b>91</b></p>	
---	--	--------------------------------------	----------------------------	---

## 6.9 Switching functions

### Work ride/Work mode (e.g. mower on)

1. G1:P (battery+) to fuse F6 (30A) (refer to Point 5 for further circuitry).
2. G1:P (battery+) flows via the fuse F5 (30A) to S1 (key-operated switch) terminal 19. If S1 is connected, B+ flows via terminal 58 to F19 (7.5A), F7 (3A) and F15 (20A).
3. B+ flows via F7 to K2:3 (seat contact control unit) and B8:2 BN (seat contact switch).  
B+ flows via F15 (20A) to K2:1 and K2:2
4. If the seat contact switch B8 is closed, K2 connects relay K9 (enable mower) via Pin 5.
5. B+ flows via fuse F19 ( 7.5A) to K1:86; B- (earth) is connected via X40 and M1:50 to K1:85. Relay K1 is connected. B+ flows via F6, K1:30, K1:87 to fuse F13 (10A) an on to switch S22 (work ride/work mode switch). B+ flows via the closed switch S22 to relay K6:86. The relay connects B+ via K6:30 to K6:87 and further to F22 (7.5A) to switch S5 (mower/fan on) and to K7:30. At the same time, B+ is connected to K7:86 via the open switch S5 (converter). Relay K7 is switched and B+ is connected via K7:30 and K7:87 to K9:30. K9 is switched by the seat contact control unit and seat contact switch. (The seat contact switch must be closed). Switch S15 (lower device support) connects B+ via S15:1 and S15:2 and diode V8 to relay K4:86. The relay switches back and enters automatic lock. Simultaneously, solenoid valve Y12 is energised via K4:30 / K4:87 and the brush unit is lowered. B+ is switched parallel to K10:86 and the mower is enabled. S15 and K10 control the mower/fan is switched off when the device support is raised and switched on again when lowered.  
When the driver leaves the seat, K9 disconnects after 1 second and K7 is released from its lock, i.e. to switch the mower/fan on again, the seat contact must be closed and switch S5 first turned to zero and then switched on again so that the mower/fan can start up again.

**Attention!**  
**Important safety function! Never bypass!**

<b>Citytrac 4200 Citymaster 1200 Citycleaner</b>	<b>Service Documents</b> For internal use only	<b>Status</b> March 2009	<b>Page</b> 92	<b><i>Hako</i></b>
--	---	-----------------------------	-------------------	--------------------

**Fault:**

**Mower does not start up:**

Is Y4 (mower/fan on solenoid valve) energised?

**Yes:** Measure coil resistance on Y4: should be 5.9 Ohm. If resistance is ok, check whether Y4 is mechanically jammed.

**Solution:** Clean; replace if necessary.

**No:** Complete following tests:

Test fuses F5, F19, F7, F15, F6, F22.

Test switches S1, B8 (seat contact) S5, S15, S22.

Test relays K1, K4, K6, K7, K9, K10. Check that B+ is applied at K2 on pins 1, 2, 3;

B- at pin 6. If the seat contact B8 is closed, B- must be connected at pin 4 via X 42 and B8. B+ must now be connected to K9:86 via pin 5. K9 closes.

<b>Citytrac 4200 Citymaster 1200 Citycleaner</b>	<b>Service Documents</b> For internal use only	<b>Status</b> March 2009	<b>Page</b> 93	<b><i>Hako</i></b>
--	---	-----------------------------	-------------------	--------------------

**Fault:**

**Engine does not start:**

Seat contact switch B8 is not actuated.  
Fuse F5, F7, F 15 or F30 is defect.  
Seat contact switch B8 is defect.

**Solution:**

Actuate seat contact switch B8  
Check fuses F5,F7,F15 and F30, replace as necessary.  
Check seat contact switch B8, replace if necessary. When the driver is seated on the seat, B8 earth ( B-) must be switched through from X42 to K2:4.  
Check the inputs at K2 are ok, check K2; replace, if necessary.

**If other tests and checks are necessary, it is essential to use the function, wiring and circuit diagrams!**

### 6.10 Controller water regulation (A5 Option Citycleaner)

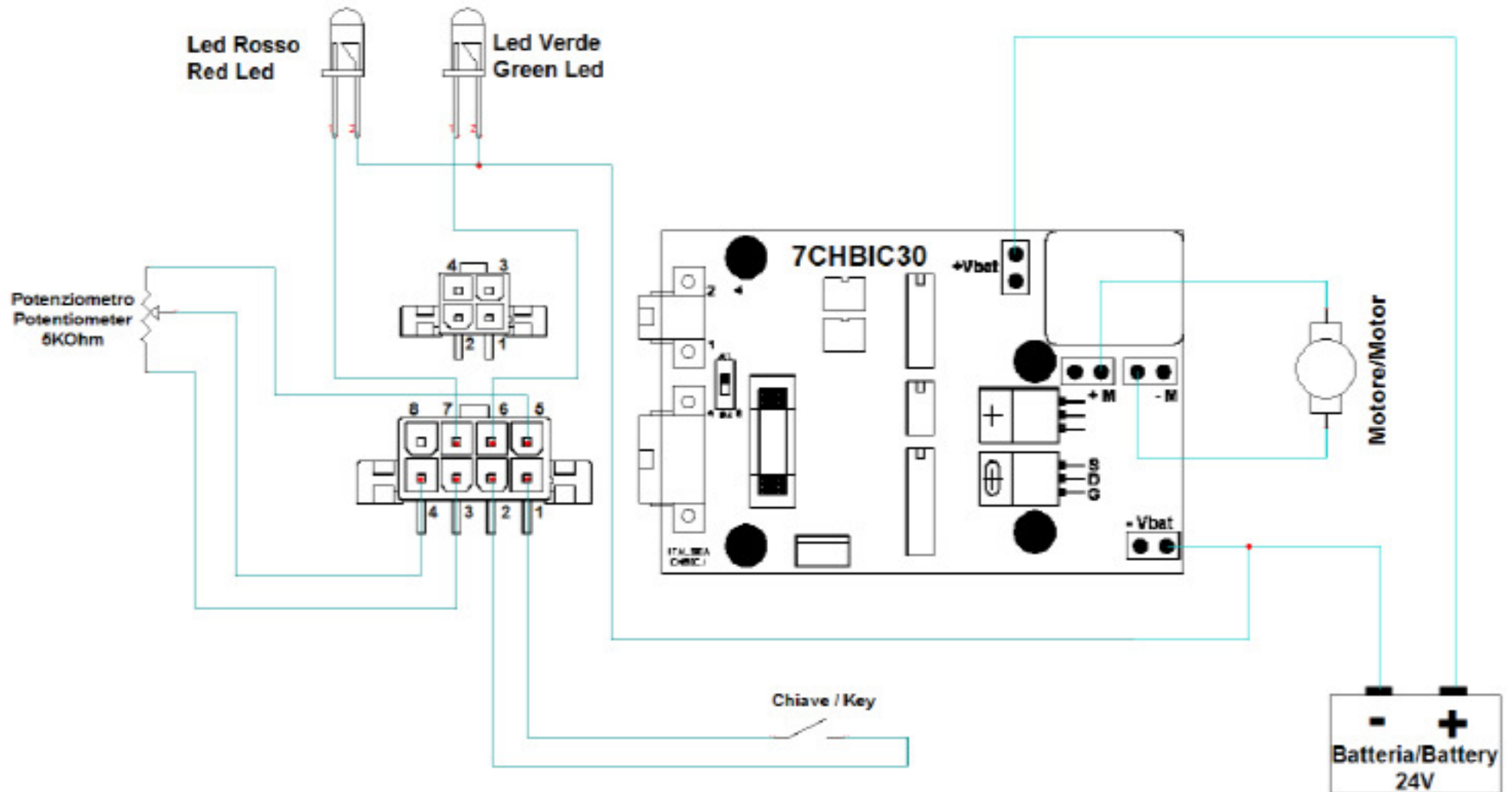

### 6.11 Relais surface pressure (A4 Option)

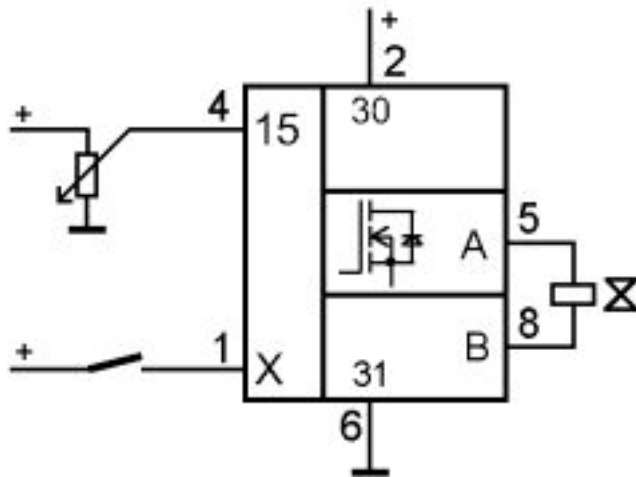

Pin	Typ	Funktion
X	2.8	Digitaleingang <i>Parameterumschaltung</i>
30	6.3	Versorgungsspannung
15	6.3	Analogeingang <i>Spannung Sollwert (0..15V)</i>
A	6.3	Ausgang <i>Proportionalventil/1</i>
31	6.3	Masse
B	6.3	Ausgang <i>Proportionalventil/2</i>

- Digital input
- Power supply
- Analog input
- Output prop. valve 1
- Ground
- Output prop. valve 2